

FRANKLIN MODEL 164 LABEL MAKER

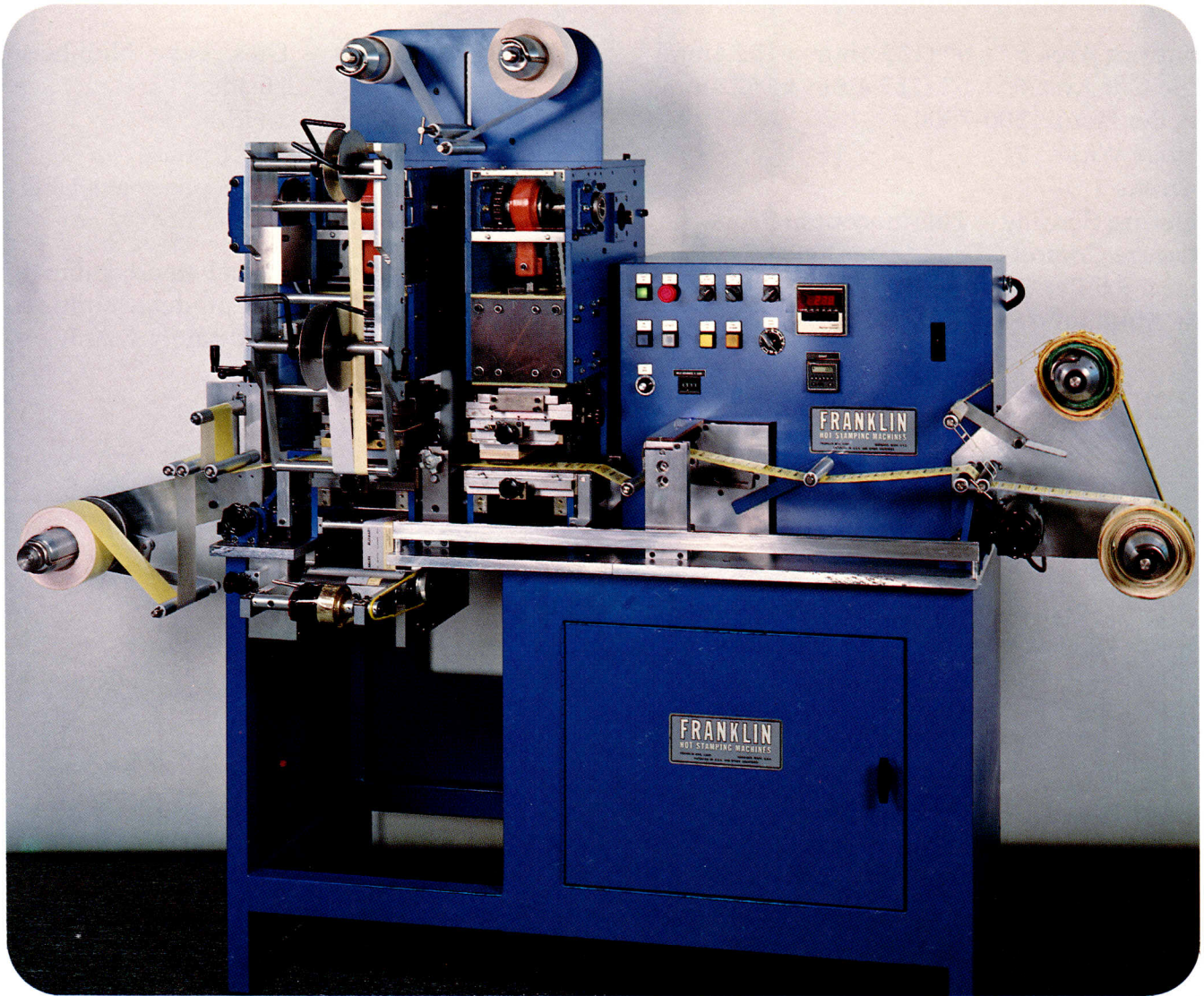

The Franklin Model 164 Hot Stamp Label Making system is the only machine that offers the following features:

1. Precision electronic registration with digital readout – adjustable while running
2. Compensating dwell-pressure control for better stamping quality
3. Multi-adjustable heads – side to side, front to back and rotational
4. Overlamine station
5. Variable electronic speed controller – can be adjusted while running
6. Automatic tension control of supply and rewind
7. Fully adjustable worktables at printing and cutting stations
8. Easy access foil rewinds at front of machine
9. Optional electronic eye reregister device for multiple passes
10. Precise front to back adjustment of web during printing cycle allows easy lineup
11. Electronic predetermining counter with digital display
12. Heavy duty steel frame
13. Manufactured in U.S.A.

FIRST IN LASTING IMPRESSIONS

SPECIFICATIONS

MODEL 164

Max. Imprint Area 6" x 6" (152.4mm x 152.4mm)
Max. Die Cut Area 6" x 6" (152.4mm x 152.4mm)
*Cycles Per Hour 1500-7500
Max. Stock Width 7"
Head Stroke 1"
Temperature Sensing – Thermocouple Probe
Temperature Control – Solid State Digital Readout
Tonnage – 6.5 Per Station
Printing Medium – Hot Stamping Foils

Printing Elements – Dies, Type, Numbering
Heads

Main Driver Motor – 1 HP

Electrical Reqs. – 220-240 1 phase

220-240 3 phase available

Weight (approx.) 1200 lbs.

Machine shipped with steel stand, cabinet, over-laminate station, electronic predetermining counter and electrically interlocked safety guards.

**Cycles per hour describes machine operating speeds. Production rates differ from cycle rates as they vary from job to job and depend on operator skill and materials.*

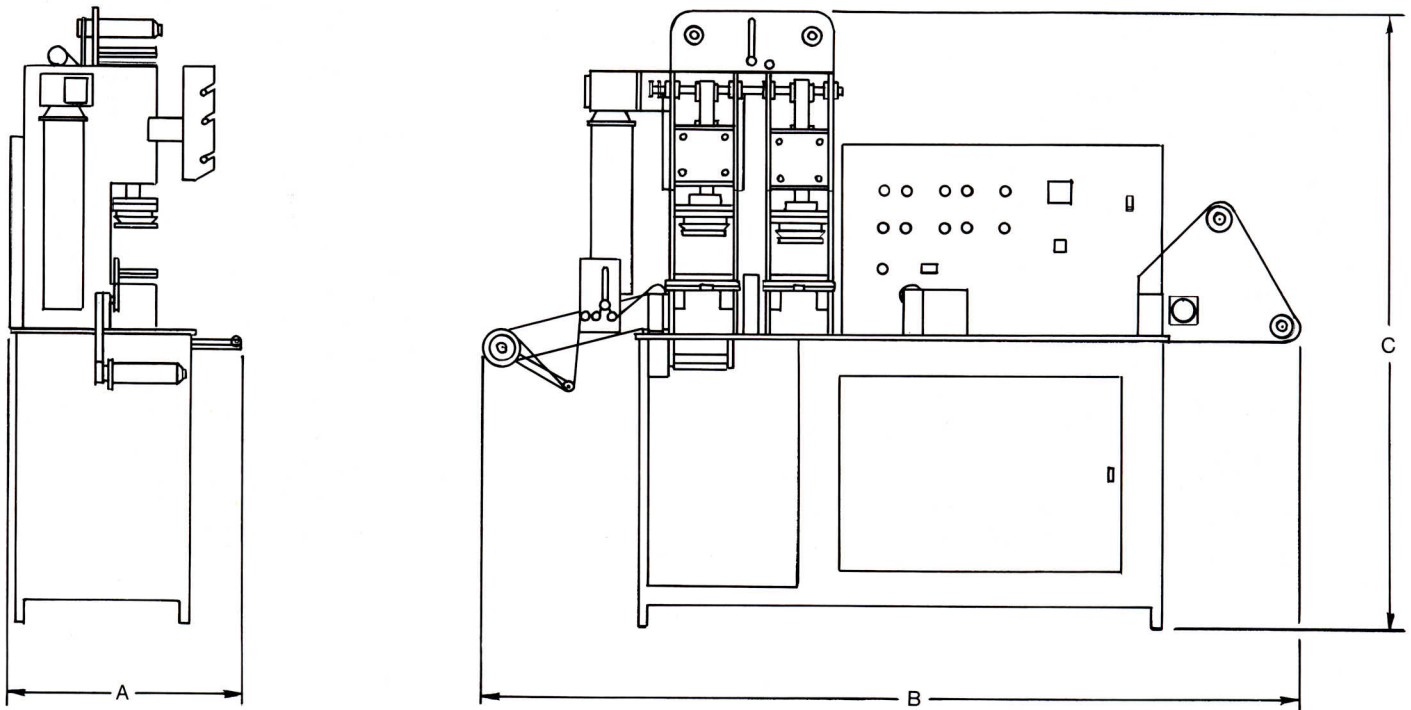

SET UP DIMENSIONS

| | A | B | C |
|--------|-------|-------|-------|
| INCHES | 30.00 | 86.50 | 70.75 |
| MM | 762 | 2197 | 1797 |

FRANKLIN
MANUFACTURING CORPORATION

P.O. Box 96, 692 Pleasant Street, Norwood, MA 02062

Telephone: (617) 769-5800 Telex: 924-337